



# SMEERPUT Type P1

## FOSSE DE GARAGE Type P1

Toepassing:  
 Smeerput, werkput en put voor remtestbank

Application:  
 Fosse mecanique et/ou vidange et fosse pour banc de freinage

### bovenaanzicht vue de dessus

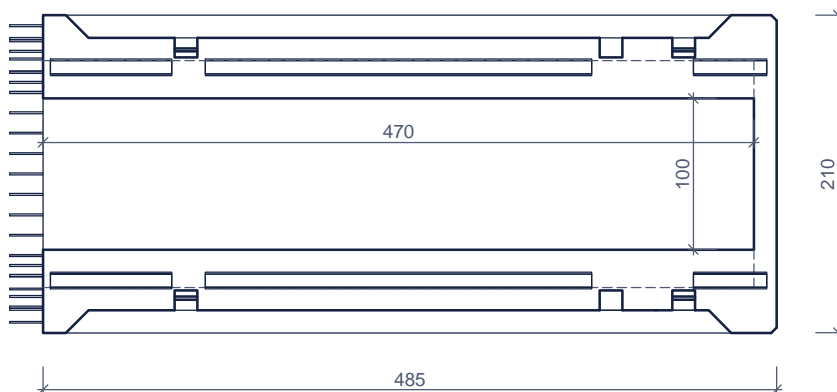

Toebehoren in optie:  
 Accessoires en option:

- Remtestbank  
Banc de freinage
- Bekisting koppeling  
Coffrage pour le raccordement
- Doorvoer  
Perforation
- Trap  
Escalier
- Sifon  
Siphon
- Profiel  
Profil

### doorsnede coupe

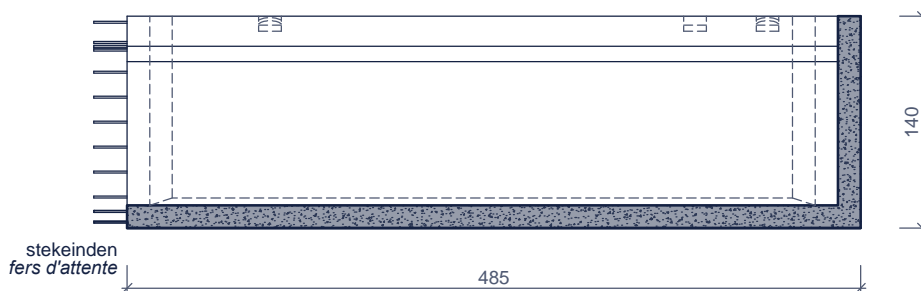

### doorsnede en vooraanzicht coupe et vue transversale

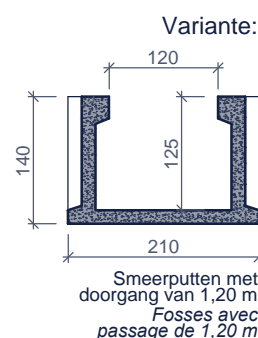
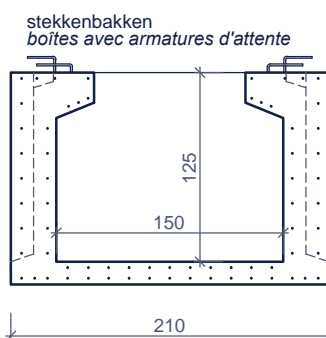
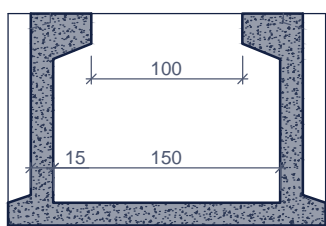

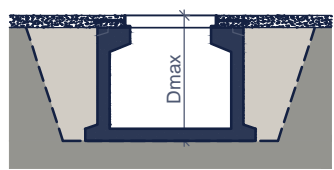
Kenmerken	SMP P1	Caractéristiques	Principe
gewicht	11.200 kg	ponds	 <p>Plaatsingsvoorschriften op aanvraag            Prescriptions de pose sur demande</p>
hijsslussen	4	points d' ancrage	
buitenafmetingen	L4,85 B2,10 H1,40 m	dimensions extérieures	
plaatsingsdiepte Dmax	2,00 m	profondeur de pose Dmax	
verkeersbelastingsklasse	D400 (NBN EN 124)	classe de charge de trafic	
omgevingsklasse	EE3+EA2 (NBN B 15-001)	classe d' environnement	
milieuklasse	XC4, XF1+XA2 (NBN EN 206-1)	classe d' exposition	

afmetingen in cm - wijzigingen voorbehouden  
 dimensions en cm - sous réserve de modifications